

XR (H/V) **EXCEL**

(1000 to 1200 cfm)
Drill More. Get More.



High Penetration, Low Fuel Costs & Trouble Free



Sustainable Productivity

Atlas Copco



Aesthetically Superior

Light weight (4300 kgs),
closed door operation
and less noise



Safety First

Heat protection and quality
cladding around the exhaust
which is placed at a
safe height



Easy Accessibility

All service points accessible
through one door.
Air Filter, Separator Element,
and Oil Filters easily replaceable



User Friendly

Radiator and Oil Cooler in a
single panel and kept side by side.
Light weight, compact and
easy to clean / service. Designed
for 50°C ambient



Spacious Canopy

Spacious canopy enables
easy serviceability,
& less number of hoses
reduce maintenance cost



Power Packed Engine

Cummins NTA-855-BC engine
with 417 HP

XR (H/V) (1000 to 1200 cfm) **EXCEL**

Drill More. Get More.

Atlas Copco is the one of the leading manufacturers of portable compressed air machines in the world. Used in a wide variety of industries, Atlas Copco has developed a set of machines that successfully walk the line between size, output and capacity.



The demand for high pressure compressors continues to rise. These compressors are particularly adapted for deep water well drilling under harsh conditions. The frame is rugged and built to last. It is perfect for building sites, both in helping lay the foundations of buildings, and ground consolidation, in addition to pipeline cleaning.

- Performance
- Transport Efficiency
- Versatility
- Resale Value
- Service Efficiency
- Safety

Enduring Performance

Compressor oil capacity of 67 liters.
Synthetic oil increases the life of screw elements, improves compression and have longer replacement interval



Compact Storage

Provision for keeping all maintenance, parts manuals, service reports and key in a compact box



Easy Access

Door enabling easy access for replacement of Fan Belt, cleaning of Radiator & Oil Cooler



Operator Panel

The Panel has all important gauges including inter-stage pressure and inter-stage temperature gauges



Unique Design

Unique un-loader design lowers engine rpm during partial load by keeping air intake fully open. Hence fuel consumption is low at partial load



Superior Technology

Efficient asymmetrical screw profile



Technical Specifications

	XRH 1000 Excel	XRH 1100 Excel	XRV 1200 Excel
Flow (l/s)	490	519	568
CFM	1035	1100	1200
Operating Pressure (psig)	275	300	330
Length (mm)	3580	3580	3580
Width (mm)	1600	1600	1600
Height (mm)	1865	1865	1865
Dry Weight (Kg)	4100	4100	4100
Engine Make / Model	Cummins / NTA 855 BC	Cummins / NTA 855 BC	Cummins / NTA 855 BC
No. of Cylinders	6	6	6
Engine Full Load Speed (rpm)	1800	1800	1900

Dimensions

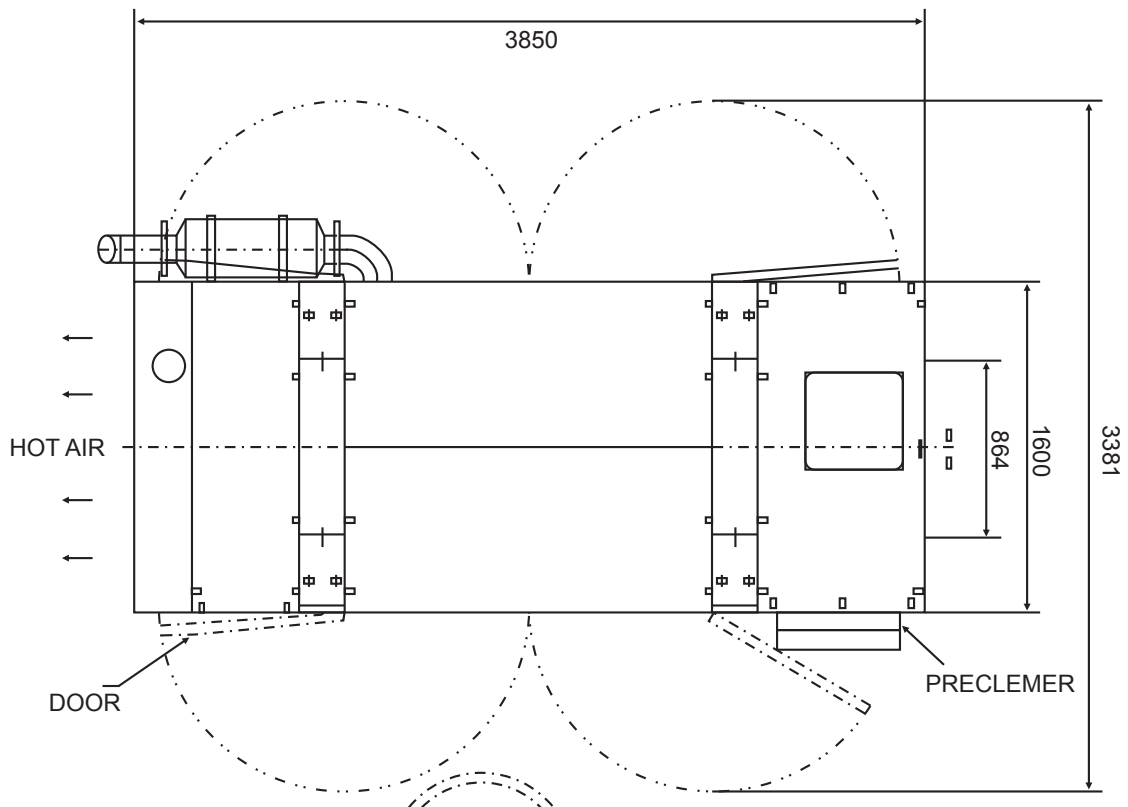

Length – 3850 mm : Width – 1600 mm : Height – 1865 mm

Waterwell Drilling



ISO 9001

From design to production and delivery Atlas Copco compressors adhere to the ISO 9001 Management Systems requirements.



ISO 14001

Atlas Copco's Environmental Management System forms an Integral part of each business process.

Atlas Copco Compressor Sales

(A Division of Atlas Copco (India) Ltd.)

Sveanagar, Dapodi, Pune 411012.

Phone: 020 - 3072 2222 Fax: 020 - 3985 7009

Email : info.compressor@in.atlascopco.com

Reach us @ 1800 200 0030

CUSTOMER CARE CENTRES	PHONE	MOBILE	FAX
406, Baleshwar Avenue, Opp. Rajpath Club, Sarkej-Gandhinagar Highway, AHMEDABAD 380 015.	(079) 32445433	(0) 9327008070	(079) 26872547
1-A, 1st Floor, Peenya Industrial Area, 2nd Phase, BANGALORE 560 058.	(080) 39280164	(0) 9379105943	(080) 39280145
SCO 811, 1st Floor, NAC, Manimajra, CHANDIGARH 161 101.	(0172) 3934922	(0) 9316915466	(0172) 3934911
"SHYAMALA TOWERS" 8th Floor, 136, Arcot Road, Saligramam, CHENNAI 600 093.	(044) 39156000	(0) 9362724009	(044) 39156004
6-3-1191, 2nd Floor, Brij Tarang, Greenland, Begumpet, HYDERABAD 500 016.	(040) 32949090	(0) 9394044056	(040) 23417923
Trinity Plaza, 2nd Floor, West Wing, 841 / 1A, Topasia Road (South), KOLKATA 700 046.	(033) 22851042	(0) 9331411141	(033) 22851043
Mahatma Gandhi Memorial Building, 2nd Floor, Netaji Subhash Road, MUMBAI 400 002.	(022) 32949090	(0) 9323177392	(022) 22811463
Unitech Business Park, Tower 'A', First Floor, Sector - 41, GURGAON 122 001.	(0124) 3027945	(0) 9312967925	(0124) 3027924
2nd Floor, Tellus Technologies Pvt. Ltd. 209/1B/1A, Range Hills Road, PUNE 411 020.	(020) 32949090	(0) 9371060934	(020) 30257129
104/1, Pallipalayam Main Road, Rajagoundampalayam, Suryampalayam PO, TIRUCHENGODE 637 211, T.N. (04288) 254575	(04288) 254575	(0) 9360543609	(04288) 254575

DEALERS : Ahmedabad, Aizwal, Amritsar, Angul, Asansol, Aurangabad, Bangalore, Barbil, Bellary, Bhopal, Bhubaneswar, Chandigarh, Chennai, Coimbatore, Daman, Dehradun, Dhanbad, Faridabad, Ghaziabad, Gwalior, Goa, Gurgaon, Hyderabad, Indore, Jaipur, Jammu, Jamshedpur, Jhansi, Kanpur, Kolhapur, Kolkata, Kullu, Kunnathur, Ludhiana, Melur (Madurai), Mumbai, Nagpur, Nasik, New Delhi, Noida, Ongole, Pathankot, Pondicherry, Pune, Raipur, Ranchi, Rourkela, Salem, Siliguri, Srinagar, Surat, Tezpur, Udaipur, Visakhapatnam, Kathmandu (Nepal), Phuntsholing (Bhutan).